

1.	Contents	Page
2.	Assembly, putting into operation, connection	3
3.	Control elements	4
4.	Display	4
5.	Factory setting	5
6.	Changing settings	6
6.1	Time and day of the week	6
6.2	Calendar month and day	7
6.2.1	AU = Automatic changeover	7
6.2.2	cHA = Weekday-related time change	8 - 9
6.2.3	no = no changeover	10
7.	Standard switching commands	11
8.	Weekday block formation	12 - 13
9.	Impulse switching commands	14 - 15
10.	Cycle switching commands	16 - 18
11.	Read - change - delete - reset	19 - 20
12.	Hand switch	21
13.	DCF77 radio operation	21
14.	Technical data	22

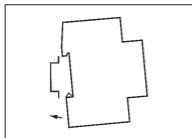

3.1 Assembly

Fit the time switch

- on a DIN rail
- optional wall surface-mounting
Surface-mounting set for 2 and 3 module spacings Article No. 03.53.0083.2

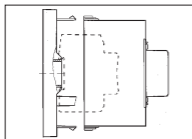

3.2 Putting into operation

The time and date are set at the factory. The time switch is in Energy-saving mode. Only the colon flashes.

Press any key:



- The time switch is activated
- It displays the time (day of the week)

3.3 Connection

See information on the unit!

Press any key to activated the timeswitch



- The time and day is displayed

Note:

If no key is pressed the time switch is automatically activated after approx. 1 - 2 minutes.

Safety instruction:

- When operating the clock safety low voltage, only safety low voltage may be connected.
- When operating the clock with function low voltage, mains voltage (230 ~) or function low voltage may be connected. The connection of safety low voltage is not admissible in this case.

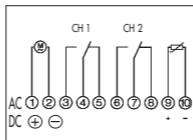
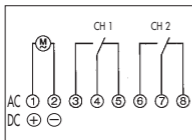
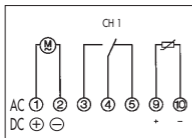
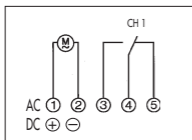

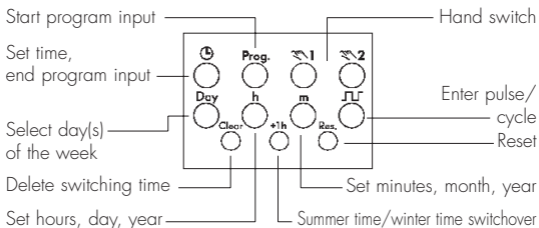

4. Display

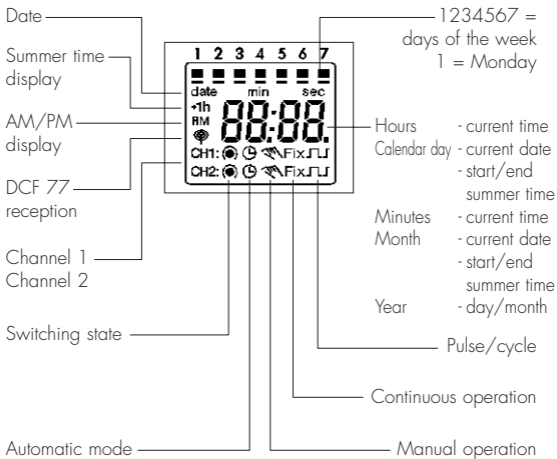

The selections correspond to Central European Time. The time switch offers 3 Operating modes. The date and time, and also the Operating mode AU are set.

Operating modes:

- **AU Automatic summer time controller switchover see 6.2.1**

The switchover occurs on the dates defined by the legislator.

- **cHA Weekday-related summer time controller switchover, see 6.2.2**

You enter the start and end dates of summer time which applies to your location/country.

e. g. The first Sunday in April of the current year
(start of summer time)

The last Sunday in October of the year
(end of summer time)

In the following years, changeover always occurs on the right day of the week in the correct calendar week.

- **no No changeover, see 6.2.3**

AM/PM switch-over

Switch clock is in current operating mode

1. Press h and keep pressed
2. – Press Res once
 - all segments are displayed
 - after approx. 1 second the following appears:
AM, 12.00 and 3 (Wednesday)
Operating mode AU is active = works setting
3. Release h
4. Select operating mode as required, see 6.2.1 or 6.2.2 or 6.2.3
5. Set the current time of day and weekday, see 6.1

Note:

You can exit/conclude any adjustments, changes you make at any time with the key .

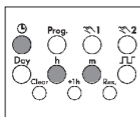
6.1 Time and day of the week

Press the  key once.

Set the time:

With the h key – hours

With the m key – minutes

Note:

If the Operating mode

no = no change
- see 6.2.3

was selected, the day of the week must **now** be set.

With the Day key select:

1 - Monday

2 - Tuesday

3 - Wednesday

:

7 - Sunday

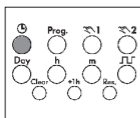
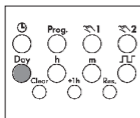

Press the  key once.
The input is ended.

6.2.1 AU or 6.2.2 cHA or 6.2.3 no

6.2.1 AU = Automatic changeover

 Press the key  once

 Press the + 1h key once,
AU appears

 Press the Prog key once

Set the current year:

With the m key or the h key



 Confirm with the Prog key

Set the current month and day:

With the m key – calendar month
With the h key – calendar day

Note:

With the Prog key (press once or twice), read the date for the start e.g. 29.03. and end e.g. 25.10. of summer time.

 Press the  key once.
The input is ended.

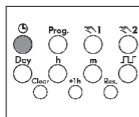
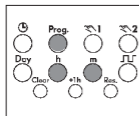
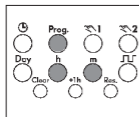
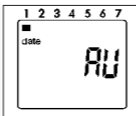
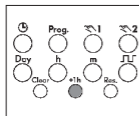
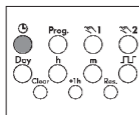

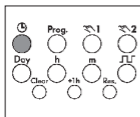

Press the key once

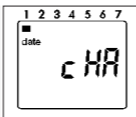
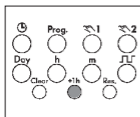

Press the + 1h key as often as necessary until **cHA** appears

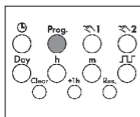

Press the Prog key once

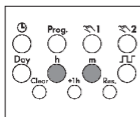

Set the current year:
With the m key or the h key

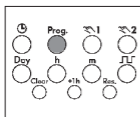

Confirm with the Prog key

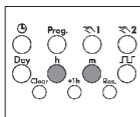

Set the current month and day:
With the m key – calendar month
With the h key – calendar day

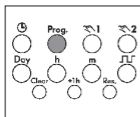

Confirm with the Prog key
The start of summer time is displayed.

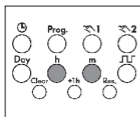

Set the individual summer time start:
With the m key – month
With the h key – day

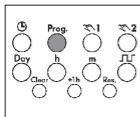

Confirm with the Prog key

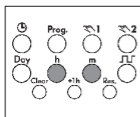

Set individual summer time end:
With the m key – month
With the h key – day

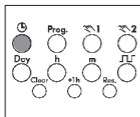

Press the  key once.
The input is ended.

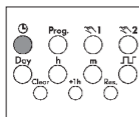

Press the  key once

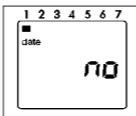
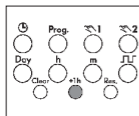

Press the + 1h as often as necessary until **no** appears. The time switch operators without a date!

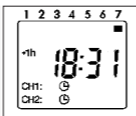
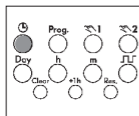

Press the  key once. The input is ended.

Note:

Select day of the week see 6.1

You determine the switching times and the switching state for the relevant switching output (channel.) Symbol: CH1: ● (ON) = Channel 1
CH2: ○ (OFF) = Channel 2

These assignments are possible:

- Switching commands **only** for channel 1
- Switching commands **only** for channel 2
- The same switching commands for channel 1 and channel 2 (the switching time and switching state are identical)
- The same switching time for channel 1 and channel 2 but with a different switching state.



Select free memory location:

Press the Prog key as often as necessary until --:-- appears.

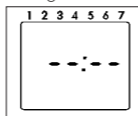

Set the switching times:

With the m key – minutes
With the h key – hours

For weekday adjustment, see:

Block formation of weekdays, Point 8

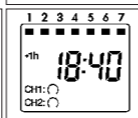

Set the switching state:

With the key
● (ON) or ○ (OFF)

Note:

The switching state for CH1 or CH2 can be deactivated.
No symbol – no switching.



Press the Prog key once. The input has ended. A free memory location is displayed – for other settings or



Press the key once. The input is ended.
The display shows the current time.

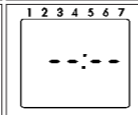
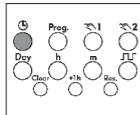
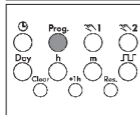
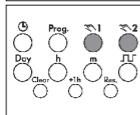
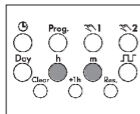

Any combination of weekdays

You determine the weekdays for your switching program.

1 - Monday, 2 - Tuesday, 3 - Wednesday ..., 7 - Sunday

Example: Monday + Wednesday + Friday (8:00 ON; 20:00 OFF)

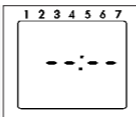
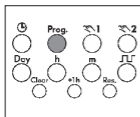

Select free memory location:

Press Prog as often as necessary until ---:-- appears

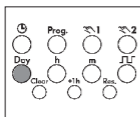

Press the Day key once
All 7 days of the week are active

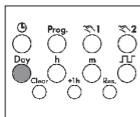

Activating/deactivating days of the week:

Press the Day key once.
There is a cursor under the number 1 (2...7)



Activate/deactivate the day of week with the Day key

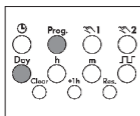

Select the next day of the week:

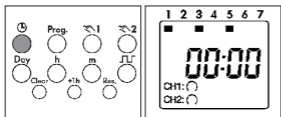

Move the cursor with the Prog key activate/deactivate the day of the week with the Day key



Press the  key once.
The weekday selection is ended.



Note:

Enter the switching times and the switching state  = ON
 = OFF
for the relevant switching state (channel).

For standard switching commands, see 7

For Impulse switching commands, see 9

For cycle switching commands, see 10



Note:

After the procedures

- read, modify or delete the time, date, switching program
- DCF synchronisation
- restoration of mains power the switching state of the time switch is updated automatically.

This means that:

- impulse switching commands from earlier times are ignored
- active cycle switching commands are re-started with the programme ON-switching time

If a load is switched ON and OFF with a high switching frequency in the seconds range, it must be ensured that effects on the quality of lighting units (flickering) and interference with radio and TV reception are avoided.

You determine the times for pulse switching commands.

These are executed once at the respective programmed time.

Symbol:  = ON switching duration (1...99 sec. or 1...99 min.)

The preselection for seconds or minutes is explained at the given time.

A pulse switching command consists of:

- Start time
- Switching ON operation

Example:

Start time Monday to Friday 09:00

ON switching duration 10 seconds

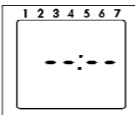
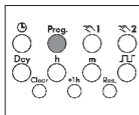

Select free memory location:

Press the Prog key as often as necessary until --:-- appears.

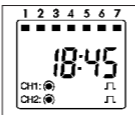
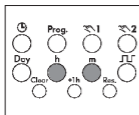



Setting the start time:

Set the day(s) of the week (see Point 8)

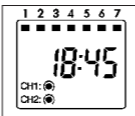
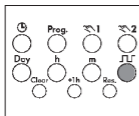
With the m key – minutes
With the h key – hours



Preselection for Pulse = 
Mark the pulse switching command with the  key (press once).

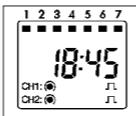
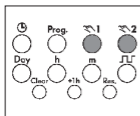

Selecting the switching output:

With the  key
CH1 and/or CH2

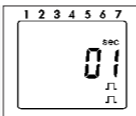
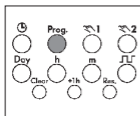

Confirm with the Prog key.

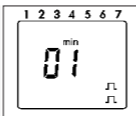
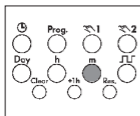

Preselection for:

- Seconds
 - Minutes
- with the m key

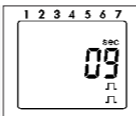
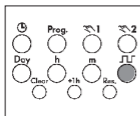

Set the ON switching duration:
With the  key 01...99

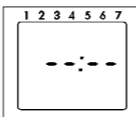
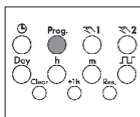

Confirm with the Prog key.

The input is ended.
A free memory location is
displayed for further settings
or

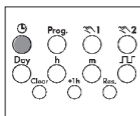

press the  key once.

The input is ended.
The display shows the current
time.

You determine the times for cycle switching commands

Symbols:  = ON switching duration (1...99 sec. or 1...99 min.)

 = cycle duration (1...99 sec. or 1...99 min.)

The preselection for seconds or minutes is explained at the given time.

A cycle switching command consists of:

- Start time
- ON switching duration
- Cycle duration (ON switching duration + pause)
- End time

An end time is only required if the cycle must be ended at a certain time. If you do **not** set an end time, the cycle switching commands operate endlessly.

1. Example:

Start time	Monday 09:00
ON switching duration	10 minutes
Cycle duration	60 minutes
End time	Friday 19:00

2. Example:

Start time	Monday to Friday 09:00
ON switching duration	10 minutes
Cycle duration	60 minutes
End time	Monday to Friday 19:00

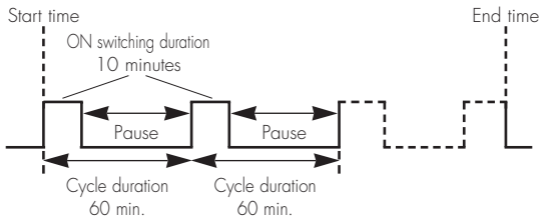

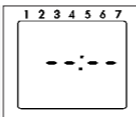
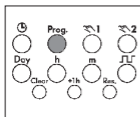

Select free memory location:

Press the Prog key as often as necessary until --:-- appears.

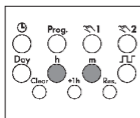

Set the start time:

Set the day(s) of the week, see 8

With the m key – minutes

With the h key – hours

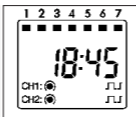
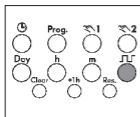

Preselection for Cycle =

Mark the cycle switching command with the key (press 2x)

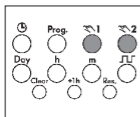

Select the switching output:

With the key
CH1 and/or CH2



Confirm with the Prog key

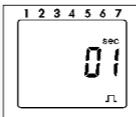
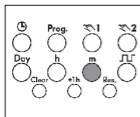

Preselection for:

- Seconds

- Minutes

with the m key

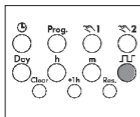

Set the ON switching duration:

With the key 01...99



Confirm with the Prog key

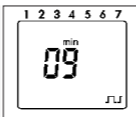
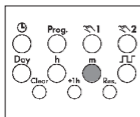

Preselection for:

- Seconds
 - Minutes
- with the m key

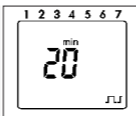
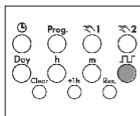

Set the ON switching duration:
with the  key 01...99

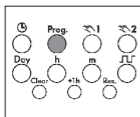

Confirm with the Prog key



A switching OFF time is displayed here with 00:00 for all 7 days of the week. You can change these individually or delete them with Clear.

The input is ended.

A free memory location is displayed for further settings or

Press the  key 1x. The input is ended.

The Display shows the current time.

Note: The next switching command in the program sequence ends the cycle. The switching command can be  = ON or  = OFF.

Note: After the procedures

- read, modify or delete the time, date, switching program
- DCF synchronisation
- restoration of mains power the switching state of the time switch is updated automatically.

This means that:

- impulse switching commands from earlier times are ignored
- active cycle switching commands are re-started with the programme ON-switching time

- You can read the program contents stepwise
- You can change or overwrite the program contents
- You can delete the program contents
- You can delete the date and time

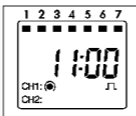
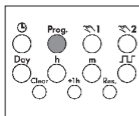
**Read**

Press the Prog key step by step
Each individual content is displayed
until the end of the program.

Then:

- One free memory location --:--
- One digit (free memory locations)
(ex. Fr 10)

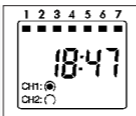
**Change**

Press the Prog key step by step as
far as the switching command/
contents which you want to change/
overwrite. Change the switching
command/contents:

As described in

8. Weekday block formation
9. Impulse switching commands
10. Cycle switching commands

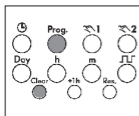
**Delete - individual switching commands**

Press the Prog key step by step as
far as the switching command/
contents which you want to delete.



Press the Clear key once.
This switching command is deleted.

Note:

You will completely delete the
cycle switching commands and
pulse switching commands when
you delete the start time.

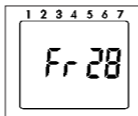

Delete - All switching commands



Press the Prog key as often as necessary until FRxx appears

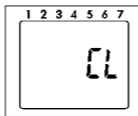

Press the Clear key once. CL is in the display

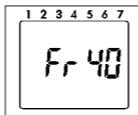

Press the Clear key and hold it down. **All memory locations are deleted!**

The display shows the number of the max. memory locations.

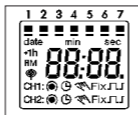

Reset



Press the Reset key once

The set date and time are reset.

The factory setting AU = automatic s/w time changeover is active (31.12.1997, 00:00)



All segments are visible for approx. 2 seconds, then 00:00 appears.













AU = automatic s/w time changeover

See point 5 and 6 for setting the current date.



You change – manually – the current switching state.
However, the individually set switching program is preserved.

-  1 for channel 1
-  2 for channel 2

 = automatic	 = Manual mode	FIX = continuous operation
  = OFF	  = ON	 FIX = Continuous ON
  = ON	  = OFF	 FIX = Continuous OFF
The switching state corresponds to the entered program.	You change – m a n u a l l y – the current switching state. The next switching command in the program is executed automatically again.	You change – m a n u a l l y – the current switching state. Only with the  key do you switch from continuous operation back to Automatic mode.

13. DCF 77 radio operation (only 3 and 6 modular spacings)

The time switch receives the time signal DCF77 with an additional antenna.

! Refer to the separate instruction !

If the time switch is synchronized, the symbol  is permanently on.

1 channel weekly program **1 channel weekly program**
2 channel weekly program **2 channel weekly program**

Dimensions (H x W x D) mm	45 x 36 x 60	45 x 54 x 60
Distributor cut-out mm	45 x 36	45 x 54
Weight g (approx.)	170	220
Connection	see unit imprint	see unit imprint
Power consumption:	see unit imprint	see unit imprint
Switching capacity at 230 V AC		
– ohmic load (VDE, IEC)	16 A/250 V AC	16 A/250 V AC
– inductive load $\cos \varphi 0,6$	2,5 A/250 V AC	2,5 A/250 V AC
– glow lamp load	1000 W	1000 W
Switching output	potential-free	potential-free
Switching contacts	1 or 2 changeover contacts	1 or 2 changeover contacts
Protection class	II	
Protection type	IP 20	
Running accuracy	± 2.5 s/day at $+20^{\circ}\text{C}$	± 2.5 s/day at $+20^{\circ}\text{C}$
DCF 77 radio operation –		with extern antenna
Running reserve type	Lithium	Lithium
Running reserve	3 years from factory	3 years from factory
Shortest switching time	1 minute	1 second
Programmable	every minute	every minute
Memory locations	30/40	30/40
Switching preselection	yes	yes
Hand switch	Automatic/preselection Fix ON Fix OFF	Automatic/preselection Fix ON Fix OFF
Pulse switching commands		1 - 99 sec./1 - 99 sec.
Cycle switching commands		1 - 99 sec./1 - 99 sec.
Switching state display	yes	yes
Block formation of weekdays	fixed definition	free assignment
Summer/winter time switchover	automatic/freely selectable	automatic/freely selectable
Connection type	captive +/- screw terminals	captive +/- screw terminals
Ambient temperature	- 25°C ... + 55°C	- 25°C ... + 55°C
led sealable	yes	yes